



Eaton's Carter Model 61525 hydrant coupler is a rugged, lightweight 4-inch coupler designed for the high flow rates used in today's hydrant systems. Model 61525 is available with a variety of options to meet most customers' requirements.

## Features

- Mates Eaton hydrant valve Models 60554, 61654 and all units in accordance with API Bulletin 1584
- Standard rigid poppet handle located in position to fit all hydrant valves without interference
- Lightweight — 19.5 lbs (8.845 kg) with 90° elbow and quick disconnect (QD)
- Mechanical interlock prevents opening of poppet until properly connected to hydrant. Cannot be removed until fully closed.
- Standard secondary collar interlock prevents "blow-off" situations
- External dust cap standard
- Plastic bumper protects metal parts
- 3 and 4-inch NPT and BSPP outlet threaded connections available. 4-inch ASSPT also available.
- Self-adjusting spring loaded nose seal
- Optional 3/4-inch NPT sense port located in elbow
- Optional folding handle
- Optional product selection
- Optional 1 3/4-inch stroke available to mate older non-standard API hydrant valves

## Superseding Data

Model 61525 supersedes and replaces the older coupler Model 60525. All options available on Model 60525 are available on Model 61525 under the same option letter, with the exception of options A (rigid handle) and E (90° elbow) on the older Model 60525. The rigid handle is standard on Model 61525. Option E includes a sense port in the elbow. Specify Option F to delete this sense port. Model 61525S replaces Model 60525-1. Model 60525 couplers can be upgraded to Model 61525 by use of a kit, KD44664-1 or KD44665-2. Refer to manual SM61525 for more details.

## Technical Data

- Suitable for operating pressures up to 200 psi (13.790 bar)
- Proof pressure — 300 psi (20.684 bar)
- Burst pressure — 500 psi (34.474 bar)
- Materials — aluminum, stainless steel, low swell Buna N (nitrile) and Teflon®
- Mates Eaton's Carter Models 60505 and 61526 adapters, Models 60554 and 61654 hydrant pit valves and all competing hydrant valves in accordance with API Bulletin 1584

## Pressure Loss Data

The pressure loss data presented, below, is derived from a single test but is adequate for system analysis. The data shown is inclusive of Model 61525 coupler and its mating part, as indicated.

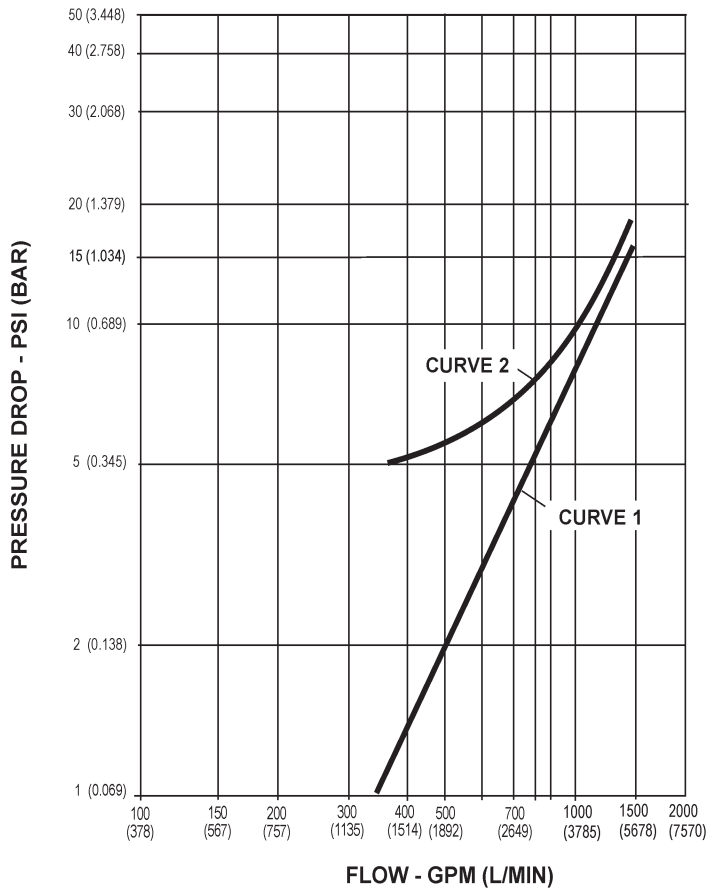

- Curve 1** Pressure loss of Model 61525 mated with Model 60505 Adapter  
**Curve 2** Pressure loss of Model 61525 mated with Model 60554D Hydrant Valve

There are two basic couplers to which various modifications may be added by option letter, as shown in the table (right). The two basic units are as follows:

### Model 61525

Basic coupler with outlet to mate with various Quick Disconnect (QD) options. Rigid operating handle (standard) and externally mounted dust cap. 2-inch stroke.

### Model 61525S

Same as Model 61525 Coupler except 1<sup>3</sup>/<sub>4</sub>-inch stroke to mate very early API valves prior to release of API Bulletin 1584.

The weight of the basic coupler is 13.0 lbs (5.897 kg)

Option Letter	Description	Weight lbs (kg)	
B	Replaces rigid handle with folding handle (41731)	-0.1	(-0.045)
C	Adds product selection (41802)	+0.1	(0.045)
E	Adds 90° elbow with 3/4-inch sense port and male half QD to mate female QD (44526) (41730-*, see option K-P)	+3.1	(1.406)
F	Same as Option E, less sense port (41622)	+3.1	(1.406)
*K	Adds 3-inch NPT female half QD with carrying handle (41730-3)	+4.0	(1.814)
*L	Adds 3-inch BSPP female half QD with carrying handle (41730-4)	+4.1	(1.860)
*M	Adds 4-inch NPT female half QD with carrying handle (41730-1)	+2.9	(1.315)
*N	Adds 4-inch BSPP female half QD with carrying handle (41730-2)	+3.2	(1.451)
*P	Adds 4-inch ASSPT female half QD with carrying handle (60740)	+2.9	(1.315)
W	Adds carriage assembly (60532B)	+6.25	(2.835)

\* Option E or F must be ordered with either options K, L, M, N or P

### Example:

61525BEK 4-inch coupler with folding handle, 3-inch NPT outlet QD with carrying handle, dust cap and collar stop assembly.  
Weight – 20.3 lbs (9.208 kg).

### Envelope Dimensions

The drawing (right) provides envelope dimensions for installation purposes only. They are not intended for inspection purposes.

Dimensions shown in inches (millimeters).

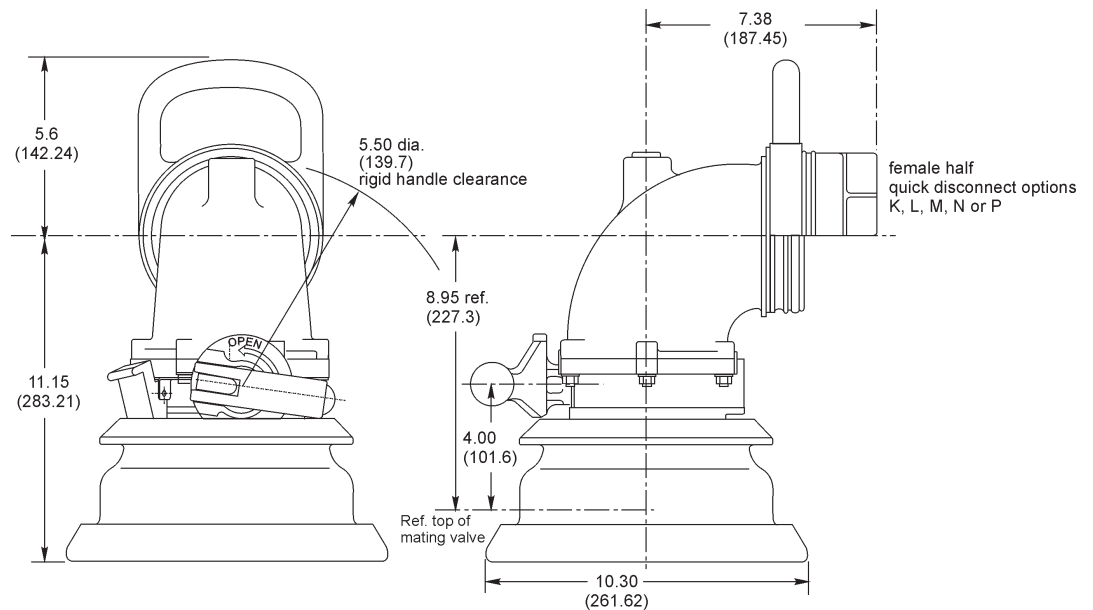

**Eaton**  
**Aerospace Group**  
**Fluid & Electrical Distribution Division**  
**9650 Jeronimo Road**  
**Irvine, California 92618**  
**Phone: (949) 452 9500**  
**Fax: (949) 452 9992**  
**E-mail: [groundfueling@eaton.com](mailto:groundfueling@eaton.com)**